

BALDOR® • RELIANCE 

Product Information Packet

IDVSM4406T-4

150HP, 1790-2685RPM, 3PH, 60-90HZ, 445T, A440

Part Detail							
Revision:	M	Status:	PRD/A	Change #:		Proprietary:	No
Type:	AC	Elec. Spec:	A44WG0183	CD Diagram:	416820-036	Mfg Plant:	
Mech. Spec:		Layout:	617427-001	Poles:	04	Created Date:	08-23-2012
Base:		Eff. Date:	12-19-2019	Leads:	3#2/0		

Specs			
Catalog Number:	IDVSM4406T-4	Feedback Device:	NO FEEDBACK
Enclosure:	TEFC	Heater Indicator:	No Heater
Frame:	445T	Insulation Class:	F
Frame Material:	Iron	Inverter Code:	Inverter Duty
Output @ Frequency:	150.000 HP @ 90 HZ	IP Rating:	NONE
	150.000 HP @ 60 HZ	KVA Code:	M
Synchronous Speed @ Frequency:	1800 RPM @ 60 HZ	Lifting Lugs:	Standard Lifting Lugs
Voltage @ Frequency:	460.0 V @ 60 HZ	Motor Lead Quantity/Wire Size:	3 @ 2/0 AWG
	460.0 V @ 90 HZ	Motor Type:	A44078M
XP Class and Group:	None	Mounting Arrangement:	F1
XP Division:	Not Applicable	Product Family:	Other
Agency Approvals:	CCSA US	Pulley End Bearing Type:	Ball
Auxillary Box:	No Auxillary Box	Pulley Face Code:	Standard
Base Indicator:	Rigid	Shaft Ground Indicator:	No Shaft Grounding
Bearing Grease Type:	Polyrex EM (-20F +300F)	Shaft Rotation:	Reversible
Constant Torque Speed Range:	1000:1	Shaft Slinger Indicator:	No Slinger
Current @ Voltage:	165.000 A @ 460.0 V	Speed Code:	Single Speed
	177.000 A @ 460.0 V	Motor Standards:	NEMA

Design Code:	A	Starting Method:	Direct on line
Drip Cover:	No Drip Cover	Thermal Device - Bearing:	None
Duty Rating:	CONT	Thermal Device - Winding:	Normally Closed Thermostat

Nameplate 000613007HV										
CAT NO	IDVSM4406T-4			SPEC NO.	P44G4009					
SER.NO.				FRAME	445T					
	HP	RPM	VOLTS	AMPS	HZ	TYPE	P			
BASE	150	1790	460	177	60	SF	1.00			
MAX	150	2685	460	165	90	INSUL.CLASS	F			
DRIVE END BEARING	90BC03J30X			CONSTANT TORQUE	DUTY	CONT	AMB	40		
OPP D.E. BEARING	6318C3VL0241			1000:1	ENCL	TEFC	PHASE	3		
DESIGN NO.	A44WG0183-R001			FLUX AMPS	66.6					
MAX SPEED/RPM	3600			OVERTEMP PROT	2	WK2	51.57		POLES	4
									WEIGHT	

Parts List		
Part Number	Description	Quantity
SA254357	SA P44G4009	1.000 EA
RA241165	RA P44G4009	1.000 EA
421948051	LABEL, MYLAR	1.000 EA
000613006PU	N/P (RELEASE QTY 10,000) UL CSA LABEL	1.000 EA
000692000VD	LABEL WARNING	1.000 EA
000613007HV	N/P BALDOR VSMMASTER	1.000 EA
089490099A	G28 BRKT 089490098WCA KB	1.000 EA
415072001B	CLAMP	1.000 EA
083199082A	G28 FAN COVER MACHINING SHORT VERSION	1.000 EA
034180014DA	KEY 1/4X1/4X1-3/4 L	1.000 EA
702618004T	FAN KB 182/70 (112) 440	1.000 EA
004824015A	GREASE POLYREX EM	1.160 LB
032018020FK	HHCS 3/4-10X2-1/2 PLTD.	4.000 EA
032018008CK	HHCS 3/8-16X1L PLATED	4.000 EA
032018030DK	HHCS 1/2-13X3-3/4 PLTD.	3.000 EA
034690002AB	PPLG 1/4" PLTD.	1.000 EA
032018030DK	HHCS 1/2-13X3-3/4 PLTD.	3.000 EA
415096002A	CPLG 1/8 HEX TYPE	1.000 EA
410700004A	WSHR	1.000 EA
034017014AB	LCKW 3/8 STD. PLATED	4.000 EA
034530064AB	P/NIP 1/8 X 8" L Pipe Nipple	1.000 EA
034530064BB	P/NIP 1/4X8 PLATED	1.000 EA
089490099A	G28 BRKT 089490098WCA KB	1.000 EA
032018020FK	HHCS 3/4-10X2-1/2 PLTD.	4.000 EA

Parts List (continued)		
Part Number	Description	Quantity
702658001A	CONDUIT BOX, E440	1.000 EA
702658002A	+C/BOX CVR, PAINTED 440	1.000 EA
415915007G	GASK, LAC	1.000 FT
406056008A	GASKET, TERBD 440	1.000 EA
418153001A	GASK 440	1.000 EA
032018008DK	HHCS 1/2-13X1 PLATED	4.000 EA
415000103D	T/LUG #4AWG-1/0AWG W/HOLE FOR .250 BOLT	1.000 EA
033512006LB	HHTTS 1/4-20X3/4 PLTD.	8.000 EA
406099000A	PLUG - FAN COVER 320-440	1.000 EA
033512004LB	HHTTS 1/4-20X1/2 PLTD.	1.000 EA
033775004EA	DRSCR #6-1/4 304 S.S.	2.000 EA
034180054KA	7/8 SQ X 6.75 KEY	1.000 EA
035000001A	ALFTG 1/8" 1610-BL	1.000 EA
034690005AB	PPLG 3/4 PLATED	1.000 EA
034690001AB	1/8" NPT SQHDPLG	2.000 EA
418151014G	RETAIN RING	1.000 EA
032018004BK	HHCS 5/16-18X1/2 PLATED	3.000 EA
035000001A	ALFTG 1/8" 1610-BL	1.000 EA
034690002AB	PPLG 1/4" PLTD.	1.000 EA
415096002A	CPLG 1/8 HEX TYPE	1.000 EA
032620016LA	SOCKET SET SCREW-449	3.000 EA
702623013A	THERMAL BARRIER -- G28 -- BRACKET MTD	1.000 EA
034017013AB	LCKW 5/16 STD. PLATED	3.000 EA
034530044AB	P/NIP 1/8X5-1/2L GALV.	1.000 EA

Product Information Packet: IDVSM4406T-4 - 150HP,1790-2685RPM,3PH,60-90HZ,445T,A440

032620016LA	SOCKET SET SCREW-449	3.000 EA
000692000FF	N/P	1.000 EA
PK5004A09	BASE 48 X 39-1/4 STACK 2 X 4 RUNNER	1.000 EA
MG1025N19	WILKO 778.50 BLUE GREEN - 55 GAL DRUMS	0.440 GA

REL S.O.	-	VOLTS	460	ENCLOSURE	TEFC	WYE	CONN EQ	CKT OHMS	PER PHASE
FRAME	445T	AMPS	177	MAX SAFE RPM	3600	(AT BASE RATING, 25 °C)			
HP	150	DUTY	CONT	IM (AMPS)	66.6	R1	.0101	X1	.100
BASE SPEED	1790	S.F.	1.00	P.F. @NL/FL	.071/.835	R2	.00736	X2	.0926
PHASE/HERTZ	3/60	AMB °C/INSUL	40/F	WK ² (lb-ft ²)	51.6			XM	3.14

RATED FULL LOAD DATA

	RPM	HP	TORQUE LB-FT	FUND VOLTS	FREQ-HZ	AMPS
BASE SPEED	1790	150	440	460	60	177
MAX SPEED	2685	150	293	460	90	165
MIN SPEED	0	0	440	7.20	.328	177

LOAD PERFORMANCE AT BASE SPEED

	RPM	HP	TORQUE LB-FT	FUND VOLTS	FREQ-HZ	AMPS
NO LOAD	1800	0	0	460	60	66.6
1/4	1797	37.6	110	460	60	92.5
1/2	1795	75.1	220	460	60	115
3/4	1793	112	329	460	60	145
FULL LOAD	1790	150	440	460	60	177
O/L	1779	299	881	460	60	325

REMARKS: TYPICAL DATA
VECTOR PWM INVERTER DUTY

 <p>A MEMBER OF THE ABB GROUP</p>	DR. BY	M. ORDERS	<p>A-C MOTOR</p> <p>PERFORMANCE DATA</p> <p>A44WG0183-R001</p> <p>ISSUE DATE 06/05/15</p>
	CR. BY	J. TSAO	
	APP. BY	J. TSAO	
	DATE	10/27/00	

C/R 343668

Printed on 6/5/15 13:56 @ bengap01

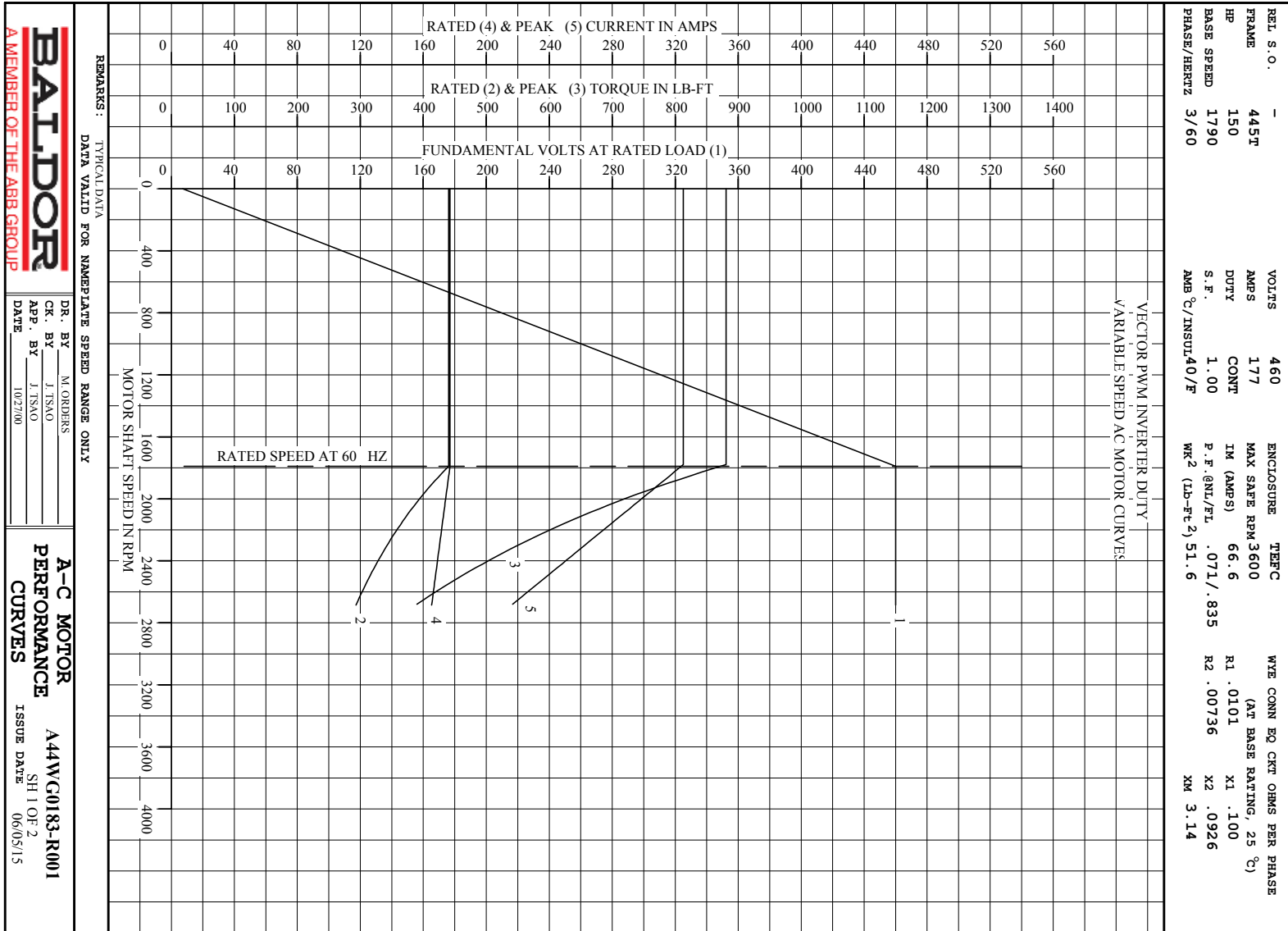

BALDOR
A MEMBER OF THE ABB GROUP

DR. BY _____ M. ORDERS CR. BY J. TSAO APP. BY J. TSAO DATE 10/27/00	A-C MOTOR PERFORMANCE CURVES A44WC0183-R001 SH 1 OF 2 ISSUE DATE 06/05/15
--	---

C/R 343668

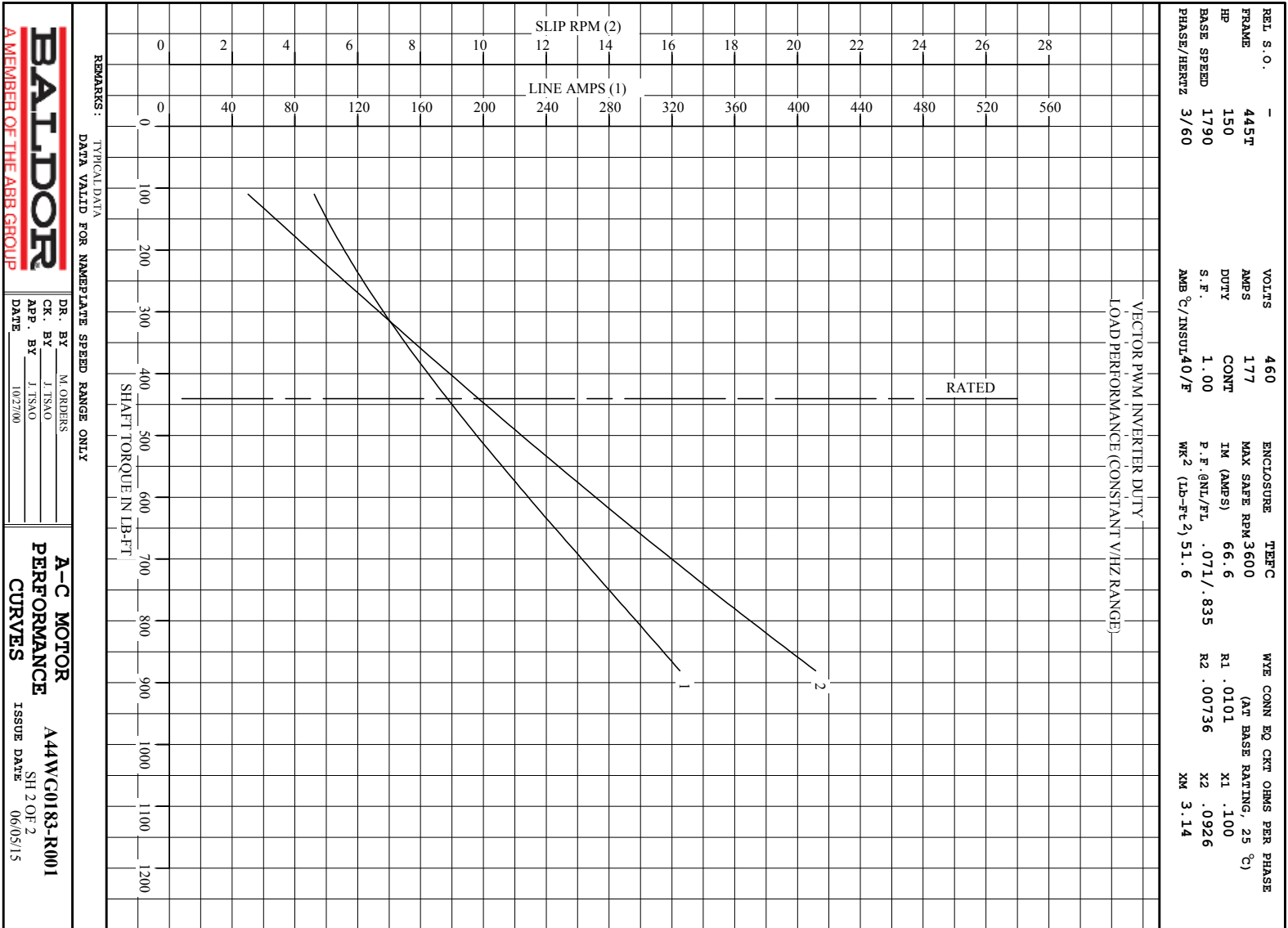

BALDOR
A MEMBER OF THE ABB GROUP

DR. BY _____ M. ORDERS
CR. BY J. TSKO
APP. BY J. TSKO
DATE 10/27/00

A-C MOTOR
PERFORMANCE
CURVES

A44WC0183-R001
SH 2 OF 2
ISSUE DATE 06/05/15

C/R 343668

617427-001

DUTY MASTER ALTERNATING CURRENT MOTORS

SQUIRREL-CAGE INDUCTION

ENCLOSURE: TOTALLY ENCLOSED

FRAME G445T ABOVE NEMA RATINGS

COOLING: FAN COOLED

MOUNTING: FOOT

INCLUDES 444T FRAME MOUNTING HOLES

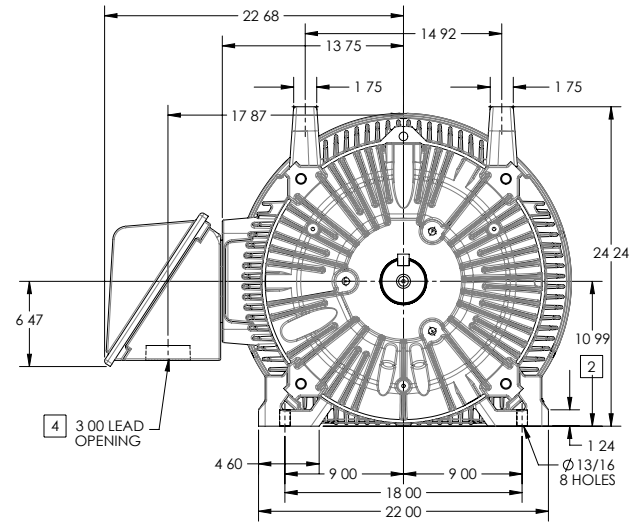
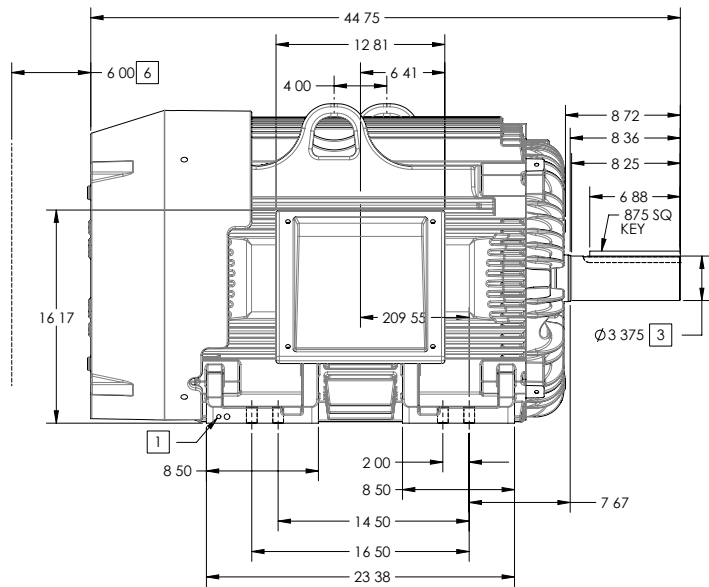

- 1 GROUND HOLES QTY 1 1/2-13 TAP; QTY 1 3/8-16 TAP
- 2 VARIES + 00 - 06
- 3 VARIES + 000 - 001
- 4 ON STANDARD MOTORS THIS IS CONDUIT SIZE ON XT AND CORROSION PROOF MOTOR THIS IS PIPE TAP
- 5 MOTOR WEIGHTS MAY VARY BY 15% DEPENDING ON RATING
- 6 OBSTRUCTION MUST NOT ENCROACH ON AIR INLET

CONDUIT BOX LOCATED ON OPPOSITE SIDE WHEN F-2
 IF MOUNTING CLEARANCE DETAILS ARE REQUIRED CONSULT FACTORY
 MAXIMUM PERMISSIBLE SHAFT RUNOUT WHEN MEASURED AT END OF
 STANDARD SHAFT EXTENSION IS .003 T I R TO 5 INCH DIA

[5] WEIGHT (LBS): 2130

DRIVE END AIR DEFLECTOR IS ONLY INCLUDED WHEN NECESSARY

DIMENSIONS ARE IN INCHES; SEE SHEET 2 FOR DIMENSIONS IN MILLIMETERS

CUSTOMER IS RESPONSIBLE FOR DETERMINING THAT MOTOR PERFORMANCE IS SUITABLE IN THE APPLICATION

SHEET NUMBER
1 OF 2

100-2742119

REV.	DESC.	SHEET 2 NEEDS METRIC FOOT HOLE DIMENSION	
REV E	VERSION 05	REVISED 09 22 56 06/12/201	TDR 00000857938
MODEL NO.	617 27-001		REF
BY RAGRA	Material		C

BALDOR

G 5/ T STD - FOOTED - SIDE/CENTER CB

617427-001

617427-001

DUTY MASTER ALTERNATING CURRENT MOTORS

SQUIRREL-CAGE INDUCTION

ENCLOSURE: TOTALLY ENCLOSED

FRAME G445T ABOVE NEMA RATINGS

COOLING: FAN COOLED

MOUNTING: FOOT

INCLUDES 444T FRAME MOUNTING HOLES

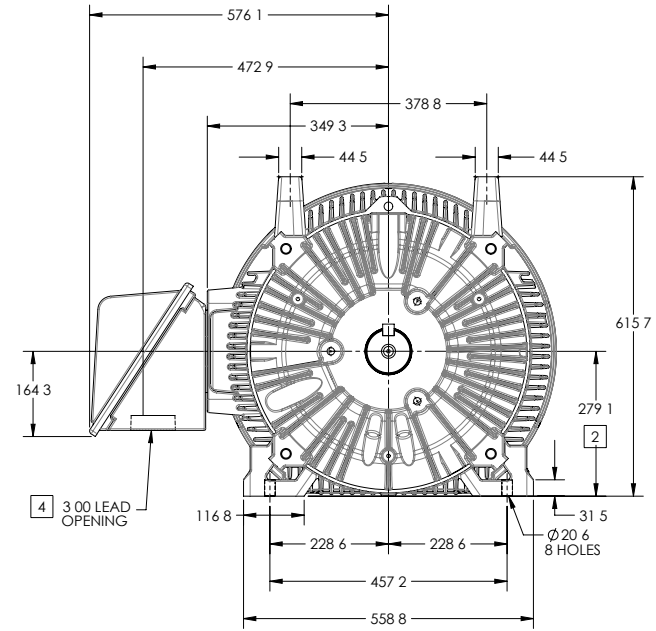
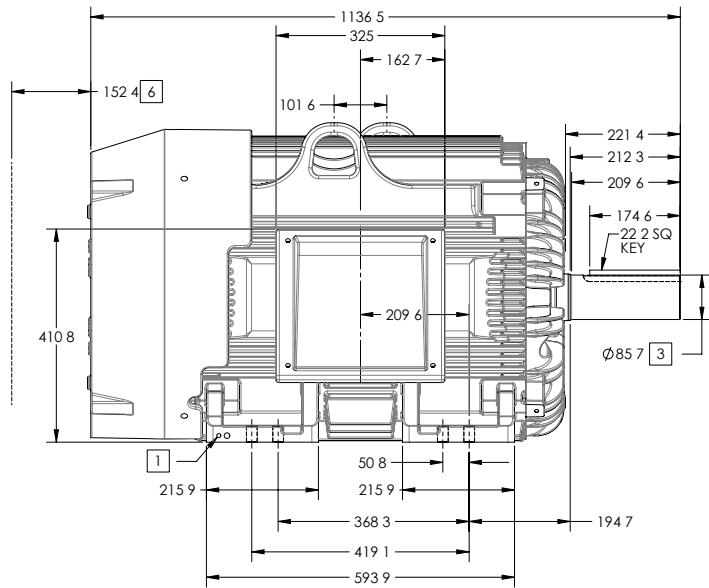

- 1 GROUND HOLES QTY 1 1/2-13 TAP; QTY 1 3/8-16 TAP
- 2 VARIES +0 -1.5
- 3 VARIES +00 -0.3
- 4 ON STANDARD MOTORS THIS IS CONDUIT SIZE ON XT AND CORROSION PROOF MOTOR THIS IS PIPE TAP
- 5 MOTOR WEIGHTS MAY VARY BY 15% DEPENDING ON RATING
- 6 OBSTRUCTION MUST NOT ENCROACH ON AIR INLET

[5] WEIGHT (KGS): 970

DRIVE END AIR DEFLECTOR IS ONLY INCLUDED WHEN NECESSARY

DIMENSIONS ARE IN MILLIMETERS; SEE SHEET 1 FOR DIMENSIONS IN INCHES

CUSTOMER IS RESPONSIBLE FOR DETERMINING THAT MOTOR PERFORMANCE IS SUITABLE IN THE APPLICATION

CONDUIT BOX LOCATED ON OPPOSITE SIDE WHEN F-2
 IF MOUNTING CLEARANCE DETAILS ARE REQUIRED CONSULT FACTORY
 MAXIMUM PERMISSIBLE SHAFT RUNOUT WHEN MEASURED AT END OF
 STANDARD SHAFT EXTENSION IS .08 MM T I R TO 127 MM DIA

SHEET NUMBER
2 OF 2

100-272119

REV. DESC SHEET 2 NEEDS METRIC FOOT HOLE DIMENSION			
REV E	VERSION 05	REVISED 09 22 56 06/12/201	TDR 00000857938
MODEL NO. 617 27-001			REF
BY RAGRA	Material		C

BALDOR

G 5T T STD -FOOTED -SIDE/CENTER CB

617427-001

416820-036

A-C MOTOR
 CONNECTION DIAGRAM
 STANDARD 3 LEAD CONNECTED

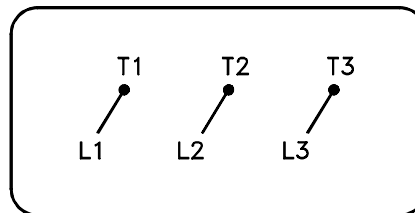

(N.P. 1575-BA)

416820-036

REV. DESC: LOADED TO BUS, C/R 335225		
REV. LTR: -	VERSION: 00	TDR: 000000538207
FILE: \MGA\00000\682	REVISED: 11:54:06 04/30/2010	
MTL: -	BY: RAGRA	

BALDOR

CONN DIAG - STANDARD 3 LEAD

SH 1 of 1